

**Deluxe X2 Ultra
Printhead Recovery
Kit**

**INSTRUCTION
MANUAL**

Revision 3.3

Deluxe X2 Ultra Recovery Kit

TABLE OF CONTENTS

<u>SECTION</u>	<u>PAGE</u>
SECTION 1: GETTING STARTED	
• WELCOME	1
• DELUXE KIT PHILOSOPHY	2
• KIT CONTENTS	5
• SAFETY	7
• DON'T DO THAT!	8
• DISCLAIMERS	9
SECTION 2: RECOVERY PROCEDURE	
• PREPARING PRINTHEAD	11
• THE MACHINE	12
• OPERATING MACHINE	13
• APPENDIX 1	19
• APPENDIX A	22
• APPENDIX B	24
• APPENDIX C	26

INTRODUCTION

WELCOME!

Thank you very much for purchasing our Deluxe X2 Ultra Recovery Kit. Many years of research have gone into producing this kit. Printhead and printer servicing prices have spiked since the economy took a downturn. It seems that printer manufacturers and dealers are not selling printers as easily as before. Some people have suggested that companies are raising their parts and service prices to make up for dwindling equipment sales revenues. Printhead prices have increased 20%-40% in the last year! As a result our recovery business is booming and our recovery kits are flying off the shelves.

We ask that before you start recovering your printheads, you read this entire manual and study the procedures. Every page has a sidebar on the right with helpful information that you should read. If you have any questions about this kit, please don't hesitate to contact us.

Thanks Again,

The Printhead Team

Solvent Resistance:

The parts in this kit that come into contact with solvent are solvent resistant. The main plastics used in this kit are Polypropylene, LDPE (Low Density Polyethylene) and HDPE (High Density Polyethylene). If you find the need to use other plastic parts in the recovery process, make sure it is one of these types of plastics. Acrylics, Polycarbonates (ie Lexan), PVC (ie. Sintra), Nylon and other related plastics are not recommended. They tend to melt and make a big mess. They also tend to solidify really well inside printhead nozzles. Clogging your nozzles with plastic would not be considered printhead recovery.

Luer Fittings

This kit makes extensive use of Luer fittings. They are a standardized small scale system of leak free connections utilizing male twist lock fittings mating with female parts. They are used extensively in medical and laboratory equipment. They were named after Hermann Luer. They are very useful, but they are not foolproof. They can still leak if not tightened completely. So check your connections.

DELUXE KIT PHILOSOPHY

OUR GOALS...

When we decided to make a Deluxe DIY Kit for our customers we researched the market extensively. We looked at machines already on the market and built many test machines before we came up with the final design. It took over two years to develop the design for this Deluxe Kit.

The machines we use in our in house recoveries are all custom built to our specifications. The parts and controls are expensive and not really suited for consumer use. We knew we would have to design a much more cost effective technology to make a consumer kit. We used some off the shelf components and adapted them to their new purpose to keep the costs down.

We have tried some machines built in China and Taiwan, but they always seem to have the following problems:

1. Many components of these machines were in constant contact with cleaning solutions and not solvent resistant. They would melt over time and the melted plastic would end up inside the printheads.
2. They had digital controls that were not reliable. Many of the circuit boards were substandard.
3. They were ineffective at recovering printheads. The ones designing the machines didn't know how to recover a printhead. They thought if you just ran some ultrasonic and pumped some liquid through the printhead it would recover itself. Printheads aren't recovered that way!
4. They had extra features that did nothing to help recover printheads. Many 'Extras' would end up breaking and causing the machines to fail.
5. The solutions they recommended to use in the machine were not effective at recovering printheads.
5. Machines were overpriced for what you get!
6. Little or no user manual
7. No support whatsoever.

We wanted to make something much better and we did. We spent two years developing this kit that not only beat the problems we saw above, but also met goals we set for a machine that would blow the socks off the competition. Our customers need a solution that works out of the box with everything they need to recover their printheads. As our technology improves we want to be able to provide upgrades to our customers that they can install themselves.

Tech in Training:

Before you get started recovering your printheads, it's important to understand what it takes to be a good tech. Whether you're a company owner or an employee it's important to not only follow directions, but to have a certain frame of mind when working with small expensive parts.

1. Follow Safety Protocols!

Always wear proper protection when working with chemicals.

2. Handle parts carefully!

You are handling sensitive parts. Be careful!

3. Patience!

Don't be in a hurry, take your time during the process.

4. Be Meticulous!

Take the time to do a complete job.

5. Stay Organized!

Keep your station organized so you don't lose any parts or cause a safety hazard.

6. Concentrate!

Pay attention to what you are doing. Turn off any distractions so you can handle the task at hand.

6. Read!

Read this manual before starting. Read your printers service manual too!

DELUXE KIT PHILOSOPHY (Cont)

OUR DELUXE KIT...

1. We created a kit with quality affordable parts.
2. All the parts that come in contact with solvents are solvent resistant.
3. Everything is modular which makes part replacements and upgrades easy.
4. Recovers printheads easily and effectively using heat, solution pumping, ultrasonic and pressurized air using our custom solutions.
5. Reliable digital controls with six automatic programs.
6. Programs recover printheads automatically.
7. Several solutions are available depending on the type of ink you use.
7. Solutions are reusable several times to help save money and keep our kits' effect on the environment minimal.
8. Includes a comprehensive manual with diagrams & pictures
9. We also have an online support centre with news, user manual updates, videos (in the near future) and knowledge base articles.
10. Our machine has a lightweight design for easy transport.
11. Clear safety protocols to help prevent operator injury.
12. Handy storage case for safe storage of machine, tools and solutions.

Our philosophy is to keep our kits inexpensive, fast, reliable, environmentally friendly, easy to upgrade and easy to use. We hope you can recovery many printheads with this kit. That way you will save literally thousands of dollars on printhead purchases. And you will get the full life out of your printheads.

Take a quick look at the side panel to see all the components that can make up your ink. Some of the components (or combinations of components) can be the cause of your head failure.

What Is Ink Made Of?

Ink is a liquid composed of some or all of the following components:

Solvents (base) - Used to suspend the other components. Can be water or a multitude of organic solvent bases.

Pigments - Larger particles of color which are floating in the base. They fade in layers.

Dyes - Smaller particles of color which are floating in the base. They are semitransparent and fade at the same time.

Resins - What makes the ink stick together or to the substrate.

Lubricants - Used in reducing friction in mechanics, distributing heat, dissolving and/or transporting particles.

Solubilizers - Increases the solubility of the ink.

Surfactants - Reduces surface tension between oil and water.

Particulate Matter - Additional particles. For instance Metallic Ink.

Drying Agents - Chemicals to speed up drying time.

Reducers - Chemicals to slow down drying time.

Fluorescers - Causing fluorescence like with fluorescent inks.

KIT CONTENTS



WHAT'S IN THE KIT!

- Eco-Solvent Solution Pack*
- Solvent Solution Pack
- UV Solution Pack*
- Waterbased Solution Pack*
- Extended Solution Pack*
- 2 Stage 1 Filters
- Pump Power Supply & Cord
- Safety Goggles
- Wipes (20)
- Round Dishes (Medium & Large)
- Toolkit
- X2 Recovery Machine
- Power Cord
- Tool Kit
- LED Flashlight
- Kit Storage Container
- Printhead Template(s)**
- Syringes (2)
- Latex Gloves (1 Box)
- User Manual
- Small Cups (3)
- Square Dish

* Which solution pack you receive will depend on the kit configuration you ordered.

** Included templates you receive depend on your kit configuration you ordered.

*** Actual contents of kit may change from description & picture shown.

THE SOLUTIONS!

Eco-Sol Solutions (1DX-4DX) - DX4 & DX5 Printhead Eco-Solvent:

1DX - Main Recovery Solution

2DX-4DX - Used for Clogs depending on Ink Type (OEM & Eco-Friendly)

Solvent Solutions (1X-4X):

1X - Used for Minor Clogs or Nozzle Deflections - Also good for Flush Solution.

2X-3X - Used for Clogs depending on Ink Type (OEM & Eco-Friendly)

UV Solutions (1UV-4UV):

1UV-4UV - Used for different types of UV ink

Water Based Solutions (1W-4W):

1W-4W - Used for Clogs depending on Ink Type (OEM, Eco-Friendly & T-Shirt)

Extended Packs on Eco-Solvent, Solvent & Waterbased:

5 Series & 6 Series - Industrial & Military grade surfactants used to recover that head which other solutions can't recover.

UNPACKING THE KIT:

The newer version of the kit comes in two packages. The storage container is in one package and the chemicals come in a separate package. If you remove all the packing materials from the storage case, all the kit contents should fit inside. It is best not to store the recovery solutions inside the machine storage container. The solutions can affect the electronics if stored for an extended period of time.

PROPER KIT STORAGE:

Your Storage Container is made of a solvent resistant plastic so you can safely store your machine and other kit contents inside. Wipe everything down with a lint free cloth before placing it into the container. Store your opened and unopened solution bottles in a nearby cool dry place outside of the storage container. Keep out of reach by children or employees that act like children.

TEMPLATE STORAGE:

Make sure to place the template parts back into the bags provided before storing them inside the container. Keeping the parts together helps you the next time.

SAFETY

PROPER SAFETY PROTOCOL

Using proper safety protocol is essential to the safe operation of this recovery kit. Safety Goggles and Latex Gloves are provided with the kit to protect eyes and hands from exposure to the chemicals. When we say Safety Goggles we don't mean Safety Glasses or Safety Shields. Goggles don't just shield the eyes, they seal against your face to prevent any pressurized chemicals from getting into your eyes. Any Safety Goggle you purchase must have air holes that are not facing forward. They should allow air to enter from the sides.

SPECIAL WARNINGS:

This deluxe kit uses an electrical fluid pump and compressed air pump. This means that the tubing could develop pressure and the luer fittings if not tightened properly could fail. Anyone standing across the room could be hit in the eyes with warm solvent.

Also, shooting compressed air into the solvent bath may cause mist to form in the bath. This mist may be harmful to your lungs.

DUE TO THESE TWO SPECIAL WARNINGS, PLEASE MAKE SURE YOU ARE IN A WELL VENTILATED AREA AWAY FROM OTHER PERSONNEL.

1. Safety Goggles and Latex Gloves must be worn at all times when using this kit.
2. Anyone watching someone using the kit must also wear Safety Goggles. That means anyone with 10 feet of the machine needs to wear Safety Goggles
3. Broken Latex Gloves must be immediately replaced to prevent skin exposure.
4. Chemical spills must be cleaned up immediately.
5. The kit should only be used in a well ventilated area.
6. Any used swabs, rags and chemical wipes should be disposed of properly in a sealed trash receptacle*.

* Disposal of chemicals and used swabs, rags and chemical wipes should be done in compliance with your government's regulations. These are the same regulations that govern the disposal of your solvent printer refuse. If you are not sure, please check with proper government officials to find out more information.

LATEX GLOVES:

If anyone using this kit has a latex allergy, please substitute Nitrile gloves for the latex gloves. Nitrile gloves are available at your local drugstore or some hardware stores.

Chemical Warning:

While the chemicals contained in this kit are not extremely hazardous or flammable, they are still considered eye irritants. Do not exposure your skin or eyes to any of these chemicals. Do not ingest any chemical or leave any of these chemicals around where young children or pets could gain access to them.

Chemistry:

These chemicals do not contain any oxidants, flammable liquids or neurotoxins.

Exposure:

Eye Contact - Flush eyes immediately with cold water. If pain or swelling develops, seek medical attention immediately.

Skin Contact - Wash affected area with cold water and soap. Avoid contact with open cuts.

Ingestion - Seek medical attention immediately.

DON'T DO THAT!

We made a special section for all the things we don't want you to do.
So please don't do them!

THE OBVIOUS ONES

- Don't submerge any or part of the machine in water or solvent to clean it or somehow help it.
- Don't hook it up to 220V unless you know for certain that this model is for 220V. If you are not sure, please ask us!
- Don't use steel wool or other abrasives to clean the X2 unit. You may damage the metal finish and cause the machine to deteriorate quickly.
- Don't heat up the bath without fluid present.
- Don't even try to run the machine without safety goggles and gloves on. While you may know what you are doing, serious injury can happen at any time. Be prepared!

LESS OBVIOUS BUT STILL IMPORTANT

- Don't use other solvents other than the ones provided to recover your printheads. The filters, pump, tubing and fittings can be damaged with improper solvents.
- Don't run the temperature of the bath over 45 degrees Celsius (30 degrees for DX4 & DX5 Printheads.) Ultrasonic energy can increase the heat enough to damage your printheads if the temperature gets too hot.
- Don't mix two solutions together to come up with some new solution. They may be incompatible with each other and cause a precipitate which will clog up the filters, etc.
- Don't store the solutions without making sure the bottles are sealed properly.
- Don't try to adapt some part to the machine that doesn't belong there. If you need assistance from us, just call us and we will help you.

Becoming a Recovery Guru:

Since we released our Standard Kit and now our Deluxe Kit we have seen people go from being at the mercy of their printer technicians to becoming recovery gurus. We have one gentleman named John that has recovered every printhead he has had to replace for the past 5 years. He has gone through 35 printheads and managed to recover all of them. His biggest problem with his Grand Format Machine was the ink. He needed to use OEM ink to keep his \$30,000 per year service contract in force. And, his contract only allowed for 2 printhead replacements in one year. He kept every last printhead until the day he found a way to recover them.

John's Tips:

1. Be Patient and don't rush the process.
2. Read the manual more than once before starting your first recovery.
3. Get your printheads into recovery before they go totally bad.
4. Have several printheads already recovered and ready to go when your printer goes south during a big job.
5. Stand next to your employees when you teach them how to use the machine and make sure they remember everything. And don't forget to wear goggles too.
6. From Time to time do a refresher course with your employees and reteach them everything they forgot.
7. Make your Technician explain everything they do and learn learn learn!

John still has his contract, but he turns in two printheads a year to get his two free ones and recovers the rest. He has saved over \$100,000 so far in new printhead costs.

DISCLAIMERS

PRINthead REMOVAL

Unfortunately, we cannot advise you on the procedure to remove/install your printhead(s) on your printer. We cannot advise you via email or on the phone to do a procedure that could result in damage to your machine if not executed properly. Also, calibration procedures are necessary after removing and reinstalling a printhead. If you are unfamiliar with these procedures, your recovered head will be out of alignment, resulting in poor print quality. It is worth the investment to hire a technician, watch, ask questions and learn the procedure.

OUR LIABILITY

We are not liable for any damage to your printer or printhead(s) resulting from removal, recovery or installation performed by you or your technician. We will also not be liable for any lost income, additional repair charges or any other resulting expense from such procedures. Anyone without the necessary knowledge should not be repairing their solvent printer.

Additionally, while many of our customers have successfully used this kit to recover their printheads, you may have different results. We are not liable for your failure to recover a printhead or for you causing a printhead to become worse after the recovery process.

WARNING

Solvent printers are high voltage devices. Anyone attempting to repair a solvent printer could receive a severe shock which might result in injury or death. Please learn the proper procedures before attempting to service your solvent printer.

Gaining Knowledge:

We can't tell you to start ripping apart your printer to learn more about it. We can give you some suggestions to gain more knowledge. We know that owning a sign shop means last minute rush jobs are a norm. Solvent Printer problems mean your client will not get his job on time. Which means a chance of getting yelled at and possibly a refund. Waiting for 2-3 days for a technician to show up and charge you \$100+ per hour for service isn't a good option either. The reality is most owners need to learn how to do "some" of the repairs themselves. Learning a little preventive maintenance would be helpful too.

Ways to Learn More:

1. Hang out with the Tech when he fixes your printer and ask him tons of questions. If he doesn't give you answers, get another tech next time.
2. Find the service manual for your printer model. It's the first step to finding out how to repair your printer.
3. Look online for as much information as you can get.
4. Find an online users group like on Yahoo.com or Google.com where like minded individuals share their knowledge and ask questions. Make sure its for your printer. Contribute what you can to the group so when it comes time to ask a question, people will want to help you. For example if you know the answer to a posted question take the time to write an answer. If you found a new media that prints great on the printer let them know. Become part of your printer's online community.

THE MACHINE

DIAGRAMS

No Goggles or Gloves needed in this section

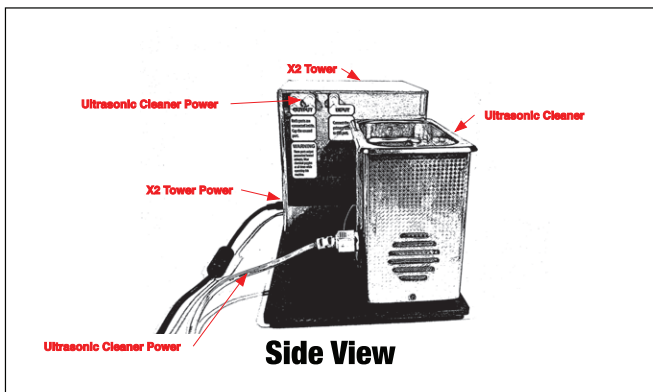
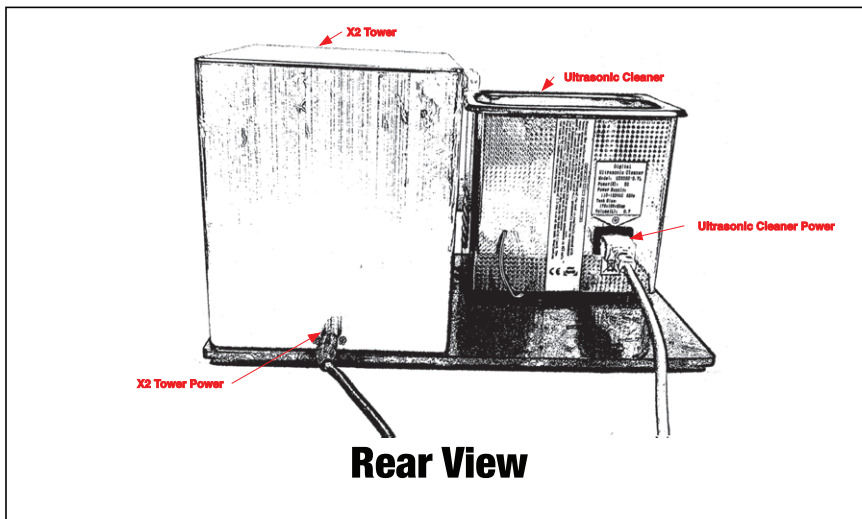
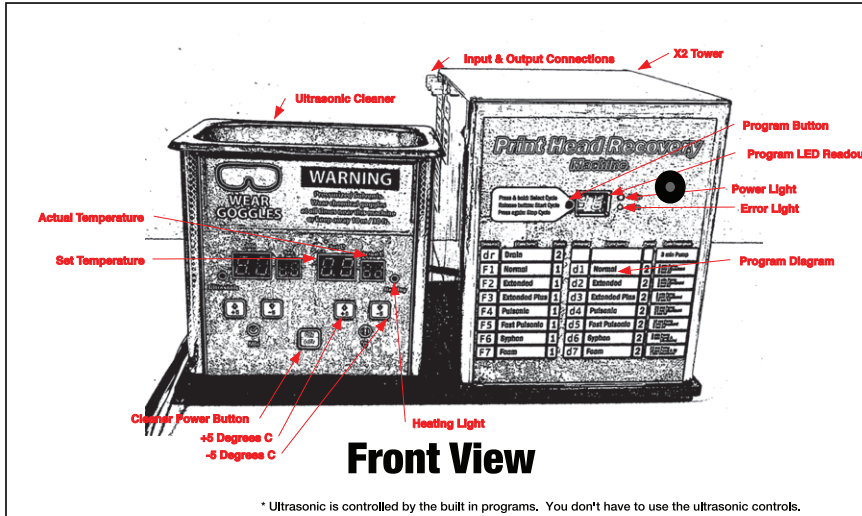

The Competition:

Our competition likes to make recovery machines that use ultrasonic and fluid pumping to recover printheads. They even have fancy stepper motors that make the printheads go up and down into the solution (BTW they break easily.) What they are mainly trying to do is loosen the clog and flush it out of the printhead. That is not easy do. The ink has deposited itself inside the printhead and basically stuck itself to the nozzle walls. It entered through a large hole and is expected to exit through a much smaller hole. Even with a ton of ultrasonic energy you can't pulverize ink down to the 80 to 30 microns(or smaller) necessary to exit the printhead nozzles. Not going to happen!

What we do:

An important step in the process is to use a solvent that breaks down some of the components of the ink (see page 3) and helps to dissolve it. We use ultrasonic, air, temperature and fluid pumping to get the solvent into the clog and allow it to dissolve the ink. Then the machine can flush out the clog once it's broken down enough.

PREPARING THE PRINthead

STEP #1: LET'S GET STARTED!

Make sure you are using Safety Goggles and Gloves.

Precleaning your Printhead

1. Test Solutions on Head

Use a lint free cloth or swab to test each of the solutions on dried ink deposits to see which one dissolves the ink best. Remember which solution you used so you can put some in the machine when it comes time to start the recovery process.

2. Pour Solution into Cup

Pour a small amount of the best solution into one of the small cups provided in the kit.

3. Pre-Clean Printhead

Carefully clean the sides and bottom of the printhead using the solution and a swab or cloth. Let the solution break down the ink and do most of the work for you.

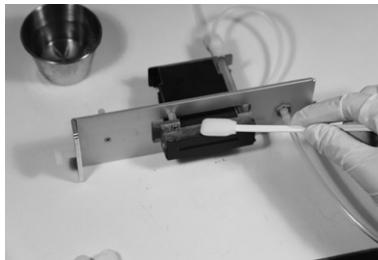

Cleaning the Electronics

1. Pour Alcohol into Cup

Pour some 90%-100% isopropyl alcohol into one of the small cups

2. Clean Electronics

Use the alcohol along with a clean swab or cloth and clean the electronic components on the printhead.

3. Use Solution for tough residue

If you simply can't break down the ink with the alcohol, clean the ink off with the solution first, then immediately switch to alcohol to wash off any solution residue.

4. Cleaning Connector

Soak the connector with a little alcohol or contact cleaner and use canned air to blow the connector out. Use Canned air until the connector is totally dry.

Why Preclean the Printhead:

Your solutions were designed to be used multiple times before buying replacements. But in order to maximize the life of the solutions you need to minimize contamination whenever possible. The dried ink on the sides and bottom of the printhead can be easily cleaned off so not to contaminate the solutions. If your printhead has a reservoir or damper which is filled with ink it would be a good idea to drain the ink out if possible. It would be one less component to recover once the recovery process starts. Also consider purchasing a new damper to replace the old one. Don't worry about cleaning out all the ink out of the printhead, just the obvious stuff.

Printhead Etiquette

Always hold your printhead firmly, like it's worth thousands of dollars. Wet gloves or wipes can cause you to lose your grip on the printhead. Don't allow it to slip out of your hands onto the table or the floor. Use only lint free wipes or foam tipped swabs (with solution) to clean the printhead. Little pieces of lint can cause deflections. Towels can cause scratches.

MACHINE OPERATION

STEP #2: TEMPLATE SETUP!

Make sure you are using goggles and gloves!

Make sure the Machine is off before starting!

1. Clean & Dry Tank

Check to make sure the recovery tank is clean and dry.

2. Put Template on Tank

Carefully place the template with the print-head attached onto the recovery machine. If the template doesn't fit nicely on top loosen the locking screw enough to allow the template to sit level on top of the machine.

3. Tighten Locking Screw

Tighten the plastic locking screw until the template is locked on the machine. Don't over tighten the screw, finger tight is fine.

4. Pour in Solution

Pour the solution you picked during the precleaning phase into the recovery tank till it reaches above the printhead nozzle plate. Make sure to recap the solution tightly after pouring to prevent spills.

5. Open the Relief Valve

Turn the black plastic relief valve knob counterclockwise to open in up all the way. Once you start the program you can turn the knob clockwise to increase the pressure to the printhead.

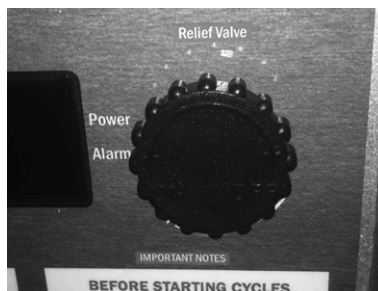
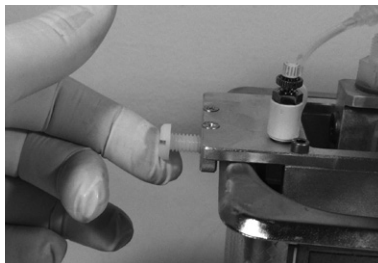

Machine Care:

Your recovery machine should last for years with proper care. Here are some steps to clean your machine after use.

1. Unplug the machine from the wall.
3. If you see any ink stains on the outside of the machine you can also use one of the solutions on a rag to clean off the stain. Depending on your solution pack, use the lowest number solution you have to clean the machine.
4. Once the ink is removed from the machine use a rag moistened with 90% Isopropyl Alcohol to wipe down the machine inside and out.
5. Dry the machine with a clean towel and place it in the storage case. Please the case in a cool, dark and dry place, away from any heat sources.

Note: Leaving solvent residue inside the stainless steel tank may cause it to oxidize over a period of time. Stainless steel is chemical resistant, but it isn't chemical proof.

MACHINE OPERATION (Cont)

STEP #3: HOSE CONNECTIONS

Make sure you are using goggles and gloves.

Check Appendix A for Hose Connection Diagrams

1. Connect Filters to Inputs on Machine

Connect both filters to the two input ports on the machine. Make sure the triangle shape arrows on the filters point into the machine.

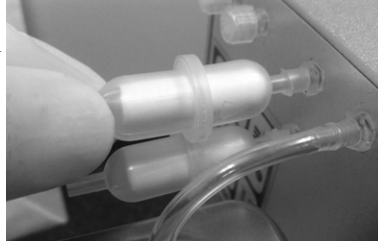

2. Connect Input hoses

Connect the input hoses to the filters and allow the ends to extend down into tank. Make sure the connects are snug so you get proper flow into the machine. The solution will flow from the tank, through the hoses and filters into the machine.

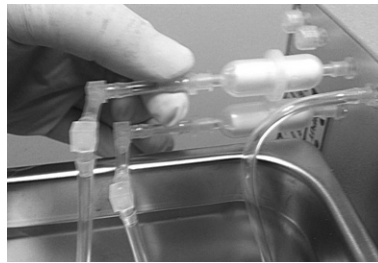

3. Connect Output Hose(s) from X2 Tower to Printhead(s)

The X2 Ultra has two outputs that you can use to connect to your printhead(s). You will use either one or two outputs depending on how many connections and/or printheads you are recovering at one time. Some larger printheads require two connections because of their size and some templates allow you to do more than one printhead at a time. If you are only using one connection, make sure and cap the other output with the provided caps to keep fluid from leaking out. The two outputs are connected together on the inside of the tower, so you will not restrict flow if you cap one of them up.



What's a relief valve?

We decided, in the spirit of not letting people cause their luer fittings to fail and solution to spew all over the place, to install relief valve in our machine. You may have partially clogged printheads or totally 100% dried up ink printheads that you need to recover. The relief valve can be opened or closed depending on the condition of the printhead. We want you start with the valve fully open and slowly close it as the printhead gets unclogged. You will use the pressure gauge to adjust the pressure to get optimum results.

What's with the two stage filtration?

We decided to use a two stage filtration system with our Deluxe X2 Ultra kit. The Stage 1 Filters are 10 micron filters that will catch all the junk before it reaches the 3 micron Stage 2 Filter on the inside of the unit. The Stage 1 Filters are cheap and the Stage 2 Filter is expensive. Stage 1's will protect your Stage 2 so it will last for a long time (depending on how many printheads you recover.)

MACHINE OPERATION (Cont)

STEP #4: RECOVERY PHASE

Make sure you are using goggles and gloves.

1. Plug in both power cords.

The machine has two power connections for proper operation. The first is a 110V (or 220V) cord that plugs into the wall and into the back of the ultrasonic Cleaner. The second is a 12V Power Supply (Brick) that plugs into the wall and into the back of the X2 Tower. Make sure both are connected properly. Once the 12V supply is connected, the power button should light up on the X2 Tower.

Note: Make sure the solution is in the machine. (Step 2 on Page 13)

If you heat the tank without fluid, you may burn it out!

2. Press the power button

Press the power button on the machine to power it on. This turns on the temperature bath. Don't touch the ultrasonic controls on the left. The controller will automatically use ultrasonic when it needs too.



3. Set tank temperature

Press the left temperature button that says + 5 degrees until the temperature readout above it says 35 degrees Celsius (**30 degrees Celsius for DX4 & DX5**). The readout on the right will show the current tank temperature. It takes a few minutes to heat up the tank to temperature.



Note: Max Temperature for DX4 & DX5 is 30 degrees - Others: 45 degrees.

4. Soak Dry Printhead

If your printhead is clogged and totally dry, soak it for 30 minutes prior to starting the recovery process.

Why Solvent Ink Clogs?

Solvent Inks can clog due to several different factors:

Drying

First of all solvent ink has resins and drying agents which make ink stick and helps it to dry. It's inherent in the ink design to find somewhere to stick and dry there.

Component Breakdown

There can be many components of an ink that are supposed to co-exist in a homogenous mixture. Over time the components break down and the chemical reactions that result can create a clog.

Evaporation

Ink components can also evaporate away leaving hard to remove clogs.

UV Inks

UV inks don't "usually" dry, but some of their components can still break down or evaporate leaving a sticky or hard mess behind. UV inks also use adhesion promoters that can clog inside of printheads.

Cleaning/Flushing Agents

Some cleaning agents provided by printer and ink companies can cause the ink to form clogs over time. The flush doesn't always break down the ink. Sometimes they just loosen the ink so it can be cleaned.

MACHINE OPERATION (Cont)

RECOVERY PHASE (cont)

Make sure you are using goggles and gloves.

Please don't rush into the recovery phase. Follow the directions below and let's do this slowly and carefully.

5. Safety Check

- Make sure that relief valve is open.
- Make sure everyone within 10 feet of the machine is wearing safety goggles and gloves. Even gloves are necessary if an emergency happens and someone close by has to handle something covered with solution.

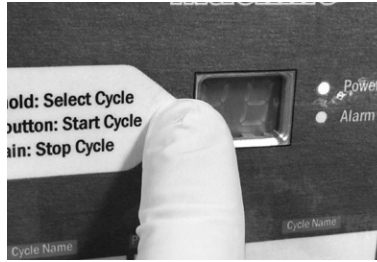

6. Check Appendix C

Appendix C has the recommended procedure to recover your printhead. You can come up with your own procedure, but for now you should follow the one outlined there.

7. Start Program

To start a program press and hold the program button to select the desired program. The programs will display in sequence as a two digit code on the LED display. Wait to the program you want shows on the display and release the program button. The program will start. The display will alternate between displaying the current program and the time left until finished. If a leak occurs or you want to shut off the program, press and release the program button. The program will terminate and pumping, ultrasonic or air blast will cease.

8. Check the fittings

Make sure the hose fittings are tight and there aren't any leaks in the system. Also make sure that fluid is not escaping the tank onto the workbench.

Explanation on Cycles

Normal Cycle

The Normal Cycle uses 3 min / 3 min / 5 sec cycles of pumping, ultrasonic and air. The pumping occurs first and tries to pump as much solution into the clogged area as possible. The ultrasonic loosens up the clogs with the help of the solution and the blast of air ejects the loosened clog. The cycle repeats for 30 minutes.

Extended Cycle

It's the same process but extends the time to 5 min / 5 min / 5 sec cycles. This Extended Cycle produced excellent results in testing just by extending the times by a few minutes. The cycle repeats for 30 minutes.

Extended Plus Cycle

It's another variation of the Extended Cycle with just a little more air time. That extra blast of air can dislodge stubborn clogs.

Pulsonic Cycle

It's a totally different process to remove the clog. The constant switching between the 3 phases with the right solution will break down the clog and flush it out.

Syphon Cycle

It's gentler cycle is excellent to help with nozzle deflections. The pumping and the pumping with ultrasonic flush the head nicely.

MACHINE OPERATION (Cont)

RECOVERY PHASE (cont)

Make sure you are using goggles and gloves.

Please don't rush into the recovery phase. Follow the directions below and let's do this slowly and carefully.

9. Watching the Pressure Gauge and Adjusting the Relief Valve

Before you start adjusting the relief valve, check the sticker on the back of the machine for the maximum pressure for the printhead you are recovering. You want the Max Pressure in MPa. Then slowly close the relief valve (clockwise) as the machine is pumping fluid. You should see the pressure gauge start to climb from zero. Keep turning until the gauge reaches the maximum pressure of the printhead. Don't adjust the pressure above the maximum pressure allowed for that printhead. If you can't reach the desired pressure, check your filters and replace them if necessary.

10. Check flow through nozzles

Loosen the thumb screw on the template and lift it part ways off the tank and check to see if solution is flowing through the nozzles.

11. Solution not Flowing Through Nozzles

If you can't seem to get any fluid to come out the nozzles, press the Program Button to stop the cycle and let the printhead sit in the bath for at least 30 minutes before trying again.

12. Flow Looks Good

If the flow through the printhead looks good, place the template back down on top of the machine and hand tighten the thumb screw.

13. Closing the Relief Valve

As the recovery progresses the flow through the printheads will increase. This will cause the pressure to drop. You should adjust the pressure to keep it at the maximum pressure until the head is fully recovered.

Explanation on Cycles(cont)

Foam Cycle

The foam cycle is another unique feature of our machine. It combines the air and solution together with a surfactant that is in some of the solutions. You can test if your solution will foam by shaking a tightly closed bottle to see if foam develops. The cycle produces a foam which is able to get deep into the printhead and dissolve the clogs. Once the surfactant is activated it can help loosen ink from inside the printhead. Just imagine turning the inside of your printhead into a slip and slide. Nothing wants to stick to the inside surfaces of the printhead.

LPRF foam-free

This cycle is used with our reverse flushing attachment to put constant pressure on the clog to flush it out. Check in the appendix for instructions on reverse flushing.

LPRF foamy

Customers asked for reverse flushing cycle with the air pump so here it is. A little blast of air couldn't hurt.

NOTE: Each cycle is affected by the running pressure. Monitor pressure to make sure it is at an optimum level.

MACHINE OPERATION (Cont)

RECOVERY PHASE (cont)

Make sure you are using goggles and gloves.

Please don't rush into the recovery phase. Follow the directions below and let's do this slowly and carefully.

14. Evaluating the Nozzles Manually

Make sure that no cycles are running before removing the template. Place the empty 6" round stainless dish on the workbench. Use a clean syringe to extract 15-30 mil from the bath to inject into the printhead. Unscrew the thumb screw and slowly remove the template from the machine. Place the head over the 6" dish and connect the syringe to the printhead hose.

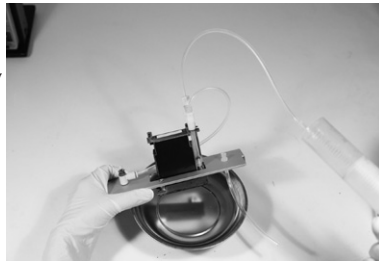

Inject the solution into the printhead and watch the nozzles shoot out the nozzle plate. You should see a steady even stream of nozzles from one side of the nozzle plate to the other. If you see some nozzle shooting off to the side instead of straight out, you will have to run additional recovery cycles to fix it (Syphon Cycle.) If you see the nozzles shooting perfectly straight, you are almost done.

15. Everything looks good. Finishing the printhead.

7. Empty the syringe completely and fill it with your ink compatible flushing solution. Inject your solution through the nozzles to check the alignment. If everything looks great, you can remove the printhead from the template and install it back into your printer.

What's a deflected nozzle?

When there is buildup inside a nozzle or on the outside, it can change the direction of fired dots so they don't exit perfectly straight from the nozzle to the media. They get deflected to one side or the other. When you inject fluid through a head, it exits the nozzle as a stream. This stream can be deflected at the same angle as a dot fired from the nozzle. With this knowledge you should be able to detect which nozzles will fire straight and which ones will not. The nozzles that fire are relatively small and hard to see. It takes a keen eye to see which nozzles are out of alignment and which ones aren't. We have a few suggestions that may help.

1. Look at the nozzle stream through directional lighting.
2. If you can use a glass & metal magnifying glass (plastic is not good to work with here) you can see the stream exiting the nozzle plate.
3. Always look at the stream at different angles to see if you can tell if some nozzles are out of alignment.
4. Run a nozzle test on the printhead in the printer to see which nozzles are not firing correctly.

APPENDIX 1

Foaming Cycle

Make sure you are using goggles and gloves.

1. Check that the template is securely locked on the machine and the hoses are connected.
2. Select the Foam cycle Program.
3. The machine will generate foam and pump it through the printhead.
4. It is recommended that you stay close by during the foaming cycle to keep an eye on the machine and not let the foaming get out of hand. Depending on environmental conditions you may generate a large amount of foam or a small amount.
5. Once the foaming cycle ends, allow the foam to subside before draining the bath. Most of the foam should turn itself back into solution.

Draining Fluids

Make sure you are using goggles and gloves.

1. Close the relief valve before draining fluids.
2. Turn ultrasonic cleaner off by pressing the power button. The display should shut off.
3. Place the open solution bottle behind the ultrasonic cleaner next to the output connectors.
4. Connect one or two output hoses to the output and run into the bottle.
5. Start the Drain program to start pumping the fluid back into the bottle.
6. Once the fluid is back into the bottle, press the Program Button to stop.
7. Open the relief valve and run the Air cycle till all fluid is in bottle.
8. Remove the template from the machine and clean all the equipment with 90% Isopropyl Alcohol immediately. Make sure everything is dry before placing the equipment into the storage container.

Proper Cleaning & Storage of the Deluxe Kit Equipment

You should carefully clean all the equipment before storing it in the storage case.

1. Remove all ink residue from the equipment.
 2. Wipe down equipment with Isopropyl Alcohol using lint free cloths.
 3. Make sure everything is dry before putting it back into the case.
 4. Test the seals of the solution bottles to make sure they are closed properly.
 5. Make sure no residual liquid is still in the tubing. You can shoot a little canned air through the lines to clear the tubing.
 6. Don't store dirty rags or swabs with the kit.
 7. Store the Stage 1 Filter with its solution container.
 8. Place the storage container in a clean dry place until the next use.
- When do I replace the solutions?**
- The most obvious time to change the solution is when it doesn't effectively recover your head. If a solution has lost 30%-50% of its volume, chances are it's not effective. If the solution has so much ink contamination it changes viscosity, it's time to change.

APPENDIX 1

Reverse Flushing(Option)

Make sure you are using goggles and gloves.

We supply the reverse flushing adapter with the necessary screws to fasten it onto the printhead. **Only use the screws supplied and use only a mini screwdriver to attach the adapter to the printhead.** A mini screwdriver will limit the torque you can put on the bolts and prevent printhead damage. We supply only one Reverse Flush adapter when you purchase this option. On dual head templates only use one RF adapter at a time.

1. Make sure printhead is securely attached to the template before proceeding.
2. Always remove the Pressure Relief Screw from the side of the RF adapter. This will allow excess pressure to escape if the head is totally clogged.
3. Make sure interior of adapter is clean, rubber pressure ring is in place, and the nozzle plate of the printhead is clean and dry.
4. Place the adapter carefully over the printhead and fasten with 2-4 screws supplied. Hand tighten screws evenly with mini screwdriver so adapter is sitting parallel to the template.
5. Place template into machine and connect adapter hose to one output. Seal other output with supplied cap. Your normal output hose from the machine to the printhead inlet will now be connected from the printhead input to the extra hose connection on your template which will deposit debris back into tank. If your template doesn't have an extra hose connection, run the hose directly into the tank behind the template. We will call this the debris hose.
6. Attach the two filters and inlet hoses as explained in Template Setup.
7. Open the relief valve all the way.
8. Run the LPRF Foam-Free cycle.

Why Reverse Flush?

Reverse flushing allows the machine to use a much higher pressure to remove clogs from your printhead. By sending the pressurized solution back through the nozzle side of the printhead and exiting the input side, you reduce the risk of blowing out the head during the recovery process. Printheads are not designed to take high pressure fluid through their normal ink feed inlets. However, the nozzle plate side of the printhead is normally reinforced and can withstand a higher pressure without being damaged. Plus, you are going in a smaller diameter nozzle output to a larger diameter printhead input. The nozzles become a built in pressure regulator. The pressures inside the head will still be within allowable levels. By back flushing the printhead you can get rid of clogs that forward flushing may not be able to achieve. We support a large range of different printheads, but we don't have a reverse flushing option for every one. Please contact us if your printhead isn't on our list and we may be able to make you one.

APPENDIX 1

Reverse Flushing(Cont)

Make sure you are using goggles and gloves.

9. Adjust Relief Valve to increase pressure to the maximum pressure indicated on the pressure chart. This will be a starting point.
10. During the cycle, check to see if debris is flowing through the debris hose. If no debris is flowing try increasing the pressure to the peak maximum pressure on the pressure chart. If no debris appears after a few minutes, adjust pressure to .15. If that doesn't work, consider changing solutions.
11. Once you have a steady amount of fluid and debris flowing through the debris tube, you can turn off the cycle and reinsert the pressure relief screw back into the adapter. Hand tighten it with a mini screwdriver.
12. Place the template back into the tank and run a new cycle.
13. Once you have a good flow a fluid through the debris tube and a no debris. Remove the adapter and do a nozzle test.

Cleaning Small Filters

Make sure you are using goggles and gloves.

This procedure can be used to clean the small filters if your filters get clogged.

1. Remove the small filters from the machine and replace them with new or previously cleaned filters.
3. While the filters are still wet, take them, a clean out hose, syringe and some distilled water and go to your nearest disposal basin. Fill the syringe with water and connect it through the hose to the filter. Make sure the connection is backwards (Reverse of arrow) from the normal fluid flow. Force the water quickly through the filter and the debris should come out. Repeat if necessary. Dry filter with canned air.

The Final Product!

1. Printhead should be free of ink deposits. If the printhead is tinted with ink, that's ok.
2. Electrical connections and circuits should be free of ink. Make sure circuits don't have any ink or solution residue. Clean all electronics with isopropyl alcohol.
3. Ribbon cables should be free of ink and solution residue. Clean with isopropyl alcohol.
4. Any internal ribbon cables or connections should be connected.
5. Printhead should not have lint particles on it.
6. Brackets should be cleaned and bolts should be tightened to tolerances.
7. All printhead nozzles should be addressable and firing properly.
8. Nozzle deflections should not be present. At most a few nozzles can be less than 1 degree from intended trajectory.
9. All printhead seals should be intact.
10. Multi-Part printheads should be reattached with parts fitting tightly and aligned properly.

APPENDIX A: FORWARD FLUSHING

FORWARD FLUSHING

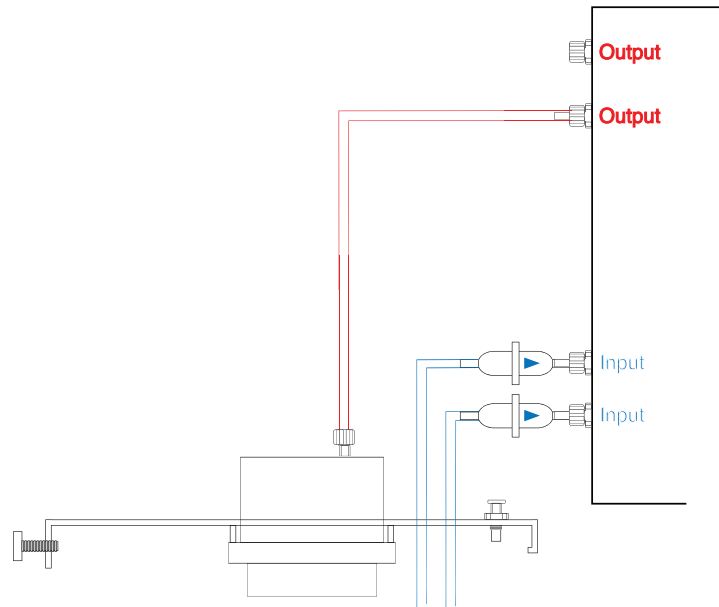

1 Port Printhead

FORWARD FLUSHING

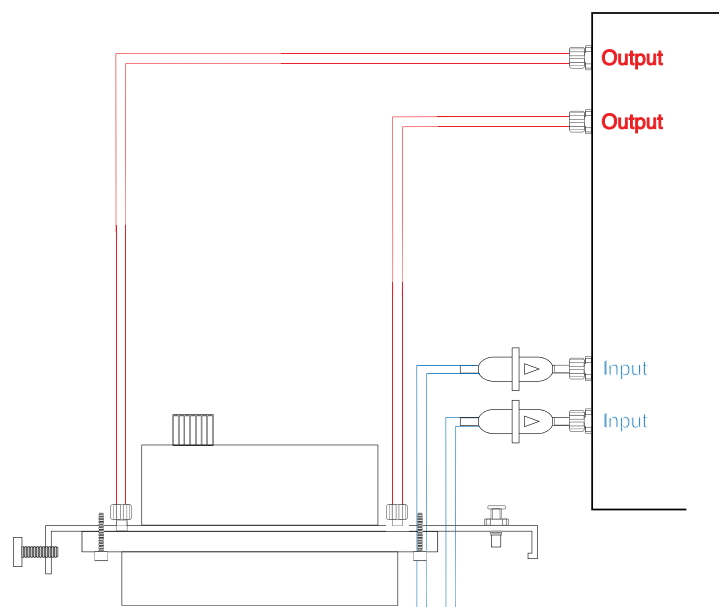

2 Port Printhead

APPENDIX A: FORWARD FLUSHING

FORWARD FLUSHING

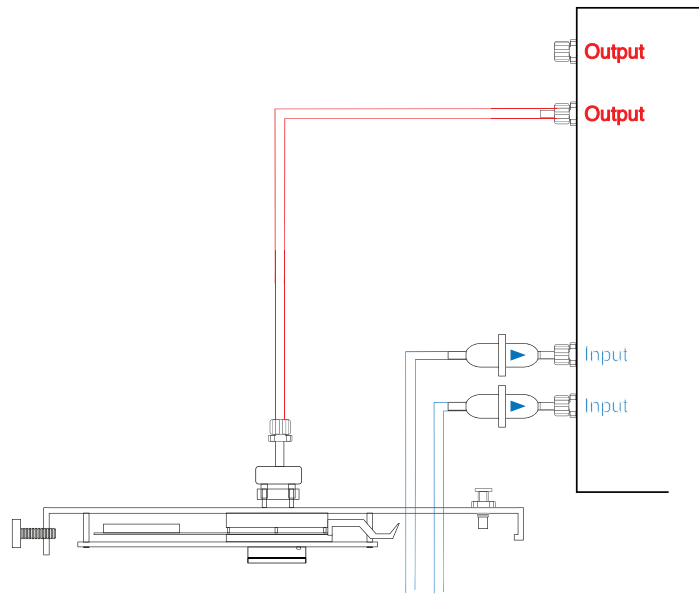

DX4

FORWARD FLUSHING

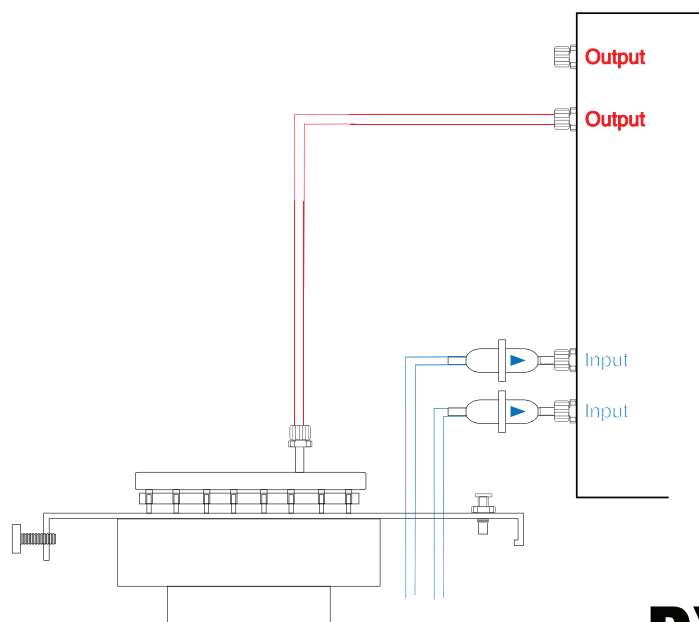

DX5

APPENDIX B: REVERSE FLUSHING

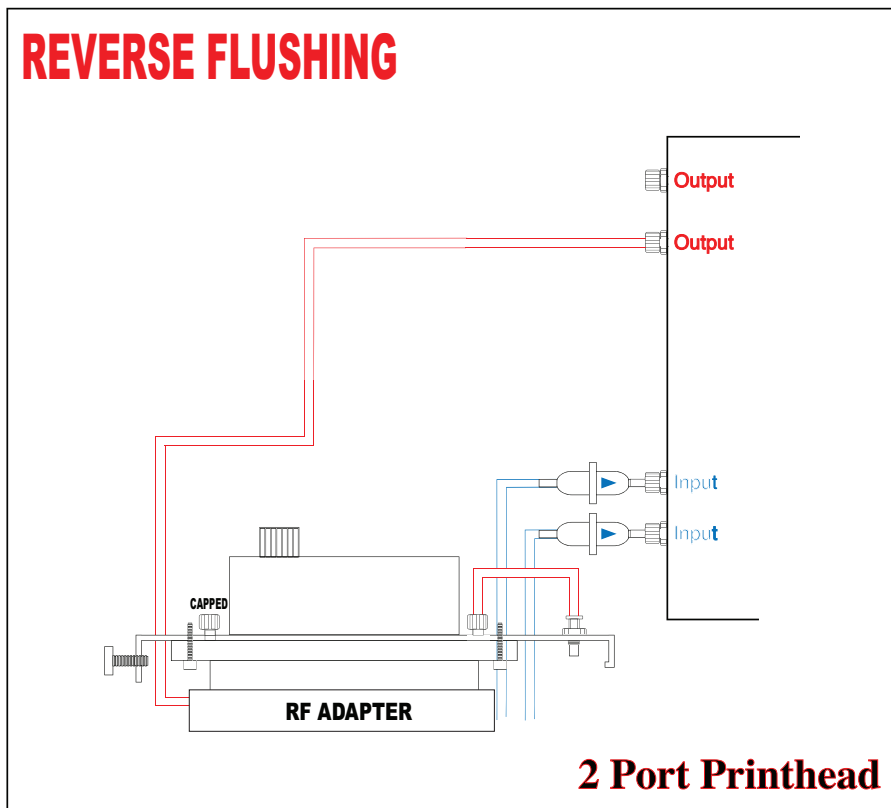
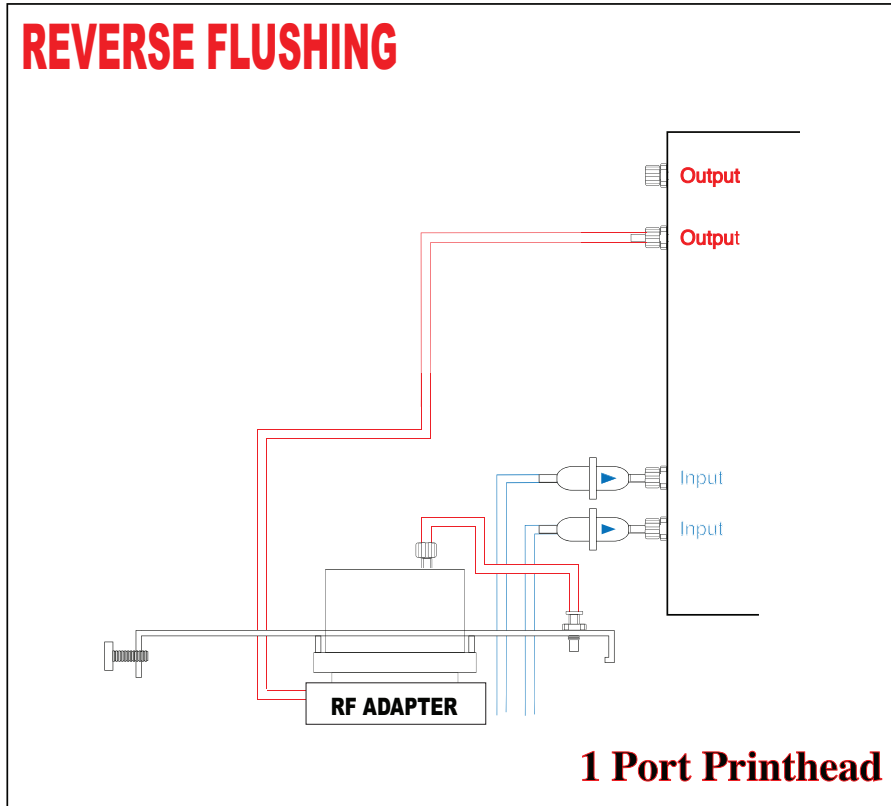

APPENDIX B: REVERSE FLUSHING

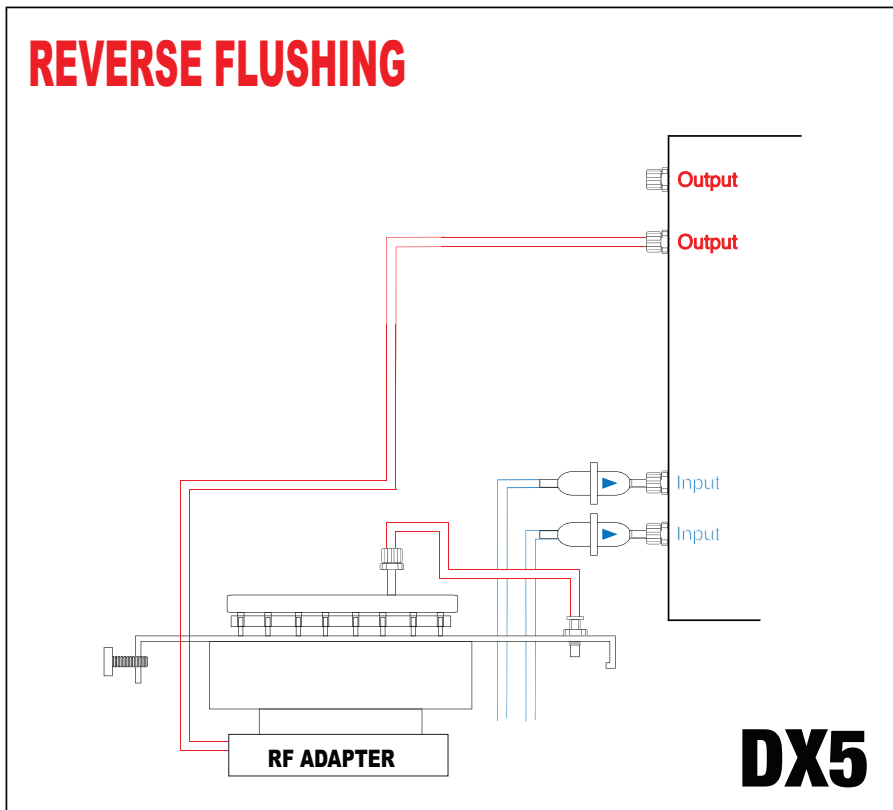
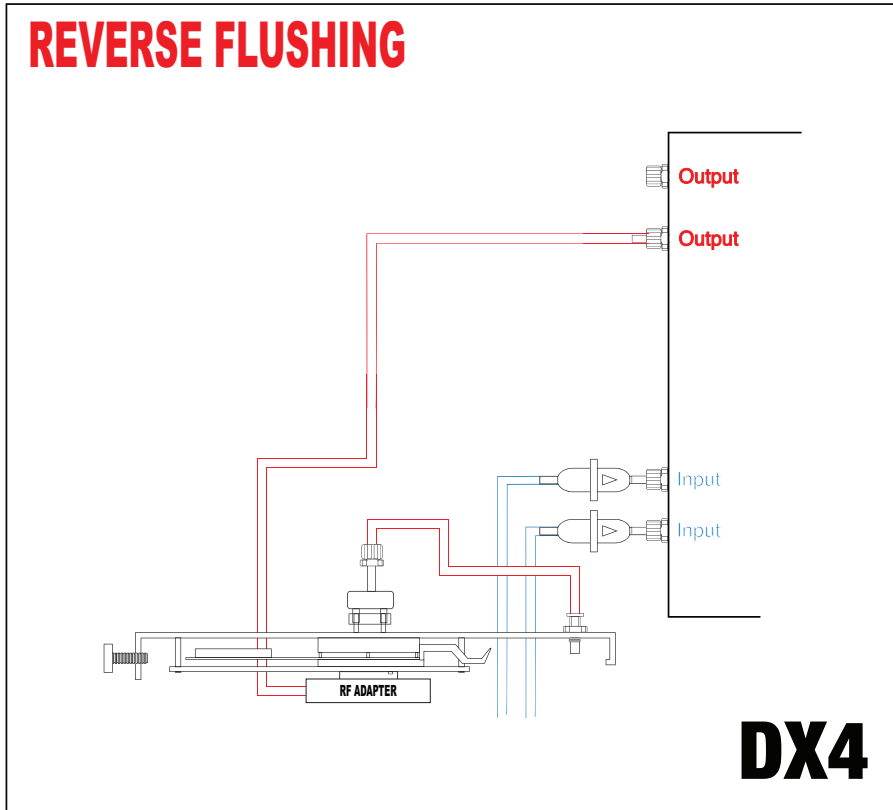

APPENDIX C

APPENDIX C: RECOVERY CHART

Program: Machine Program displayed on X2 Tower Readout
Note: Checking Nozzles - Unscrew Thumbscrew and lift printhead out of machine while DR program is running. Check to see how many nozzles are shooting.
Eval: Evaluate printhead nozzle streams for clogged nozzles. Streams should be straight

FORWARD FLUSHING

Printhead Types: Spectra, Xaar, Konica, Toshiba, Hitachi, Seiko
Wet Clogged Printhead: Start Step 1 / Dry Clogged Printhead: Soak 30 Minutes First

Step	Program	Pressure	Cycles	Temp	Comments
1	F1	1/2 Max	1-2	35°	Good Initial Program
2	DR	1/2 Max	1	35°	Lift head & Check Nozzles
3	Evaluate	Unclogged: Step 11 / Clogged: Step 4			
4	F1, F2 or F3	3/4 Max	1-2	35°	Try a few times
5	DR	3/4 Max	1	35°	Check Nozzles Again
6	Eval	Unclogged: Step 11 / Clogged: Step 7			
7	F4 or F5	Max	1-2	35°	Try a few times
8	DR	Max	1	35°	Check Nozzles Again
9	Eval	Unclogged: Step 11 / Clogged: Step 10			
10	Changes: 1st Round: Change Temp to 45° 2nd Round: Change Solution -> Step 1				
11	F6	Max	1-3	35°	Use D1, D2 or D3
12	DR	Max	1	35°	Check Nozzles Again
13	Eval	No Deflections Step 15 / Yes Deflections Step 14			
14	Changes: 1st Round: Temp 45° 2nd Round: Change Solution -> Step 11				
15	Hand Flush	N/A	Flush Head (Syringe): With your ink Flush		

GREEN: LOW RISK YELLOW: MODERATE RISK BLUE: Change Something
RED: HIGHER RISK ORANGE: VISUAL INSPECTION

Printhead Types: DX4 & DX5
Wet Clogged Printhead: Start Step 1 / Dry Clogged Printhead: Soak 30 Minutes First

Step	Program	Pressure	Cycles	Temp	Comments
1	F1	1/2 Max	1-2	30°	Good Initial Program
2	DR	1/2 Max	1	30°	Lift head & Check Nozzles
3	Evaluate	Unclogged: Step 11 / Clogged: Step 4			
4	F1, F2 or F3	1/2 Max	1-2	30°	Try a few times
5	DR	1/2 Max	1	30°	Check Nozzles Again
6	Eval	Unclogged: Step 11 / Clogged: Step 7			
7	F4 or F5	3/4 Max	1-2	30°	Try a few times
8	DR	3/4 Max	1	30°	Check Nozzles Again
9	Eval	Unclogged: Step 11 / Clogged: Step 10			
10	Changes: 1st Round: Change Temp to 45° 2nd Round: Change Solution -> Step 1				
11	F6	Max	1-3	30°	Use D1, D2 or D3
12	DR	Max	1	30°	Check Nozzles Again
13	Eval	No Deflections Step 15 / Yes Deflections Step 14			
14	Possible Change: 2nd: Change Solution -> Step 11				
15	Hand Flush	N/A	Flush Head (Syringe) with your flush		

GREEN: LOW RISK YELLOW: MODERATE RISK BLUE: Change Something
RED: HIGHER RISK ORANGE: VISUAL INSPECTION

APPENDIX C

APPENDIX C: RECOVERY CHART

Program: Machine Program displayed on X2 Tower Readout
Note: Checking Nozzles - Unscrew Thumbscrew and lift printhead out of machine while DR program is running. Check to see how many nozzles are shooting.
Eval: Evaluate printhead nozzle streams for clogged nozzles. Streams should be straight

REVERSE FLUSHING

Printhead Types: Spectra, Xaar, Konica, Toshiba, Hitachi, Seiko

Wet Clogged Printhead: Start Step 1 / Dry Clogged Printhead: Soak 30 Minutes First

Step	Program	Pressure	Cycles	Temp	Comments
1	Change: Remove Pressure Screw from RF Adapter -> Step 2				
2	LPRF	1/2 Max	1-2	35°	RF Program - No Pressure Screw
3	Check Fluid Flow thru Debris Hose (Hose from Printhead to bath)				
4	Evaluate	Debris Hose Flow Good: Step 8 / No Flow: Step 5			
5	LPRF	3/4 Max	1-2	35°	Try a few times
6	Check Fluid Flow thru Debris Hose (Hose from Printhead to bath)				
7	Eval	Debris Hose Flow Good: Step 8 / No Flow: Step 12			
8	Change: Insert Pressure Screw into RF Adapter -> Step 9				
9	LPRF	Max	1-2	35°	RF Program - W/Pressure Screw
10	Check Fluid Flow thru Debris Hose (Hose from Printhead to bath)				
11	Evaluate	Debris Hose Flow Good: Step 13 / No Flow: Step 12			
12	Changes: 1st Round: Change Temp to 45° 2nd Round: Change Solution -> Step 1				
13	Goto Forward Flushing on Page 26				

GREEN: LOW RISK YELLOW: MODERATE RISK BLUE: Change Something
RED: HIGHER RISK ORANGE: VISUAL INSPECTION

Printhead Types: DX4 & DX5

Wet Clogged Printhead: Start Step 1 / Dry Clogged Printhead: Soak 30 Minutes First

Step	Program	Pressure	Cycles	Temp	Comments
#REF!	Change: Remove Pressure Screw from RF Adapter -> Step 2				
2	LPRF	1/2 Max	1-2	30°	RF Program - No Pressure Screw
3	Check Fluid Flow thru Debris Hose (Hose from Printhead to bath)				
4	Evaluate	Debris Hose Flow Good: Step 8 / No Flow: Step 5			
5	LPRF	3/4 Max	1-2	30°	Try a few times
6	Check Fluid Flow thru Debris Hose (Hose from Printhead to bath)				
7	Eval	Debris Hose Flow Good: Step 8 / No Flow: Step 12			
8	Change: Insert Pressure Screw into RF Adapter -> Step 9				
9	LPRF	Max	1-2	30°	RF Program - W/Pressure Screw
10	Check Fluid Flow thru Debris Hose (Hose from Printhead to bath)				
11	Evaluate	Debris Hose Flow Good: Step 13 / No Flow: Step 12			
12	Change Solution -> Step 1				
13	Goto Forward Flushing on Page 26				

GREEN: LOW RISK YELLOW: MODERATE RISK BLUE: Change Something
RED: HIGHER RISK ORANGE: VISUAL INSPECTION

APPENDIX C